

<b>LEVELING CASTER</b> 높낮이 조절용 캐스타	<b>FOOT MASTER®</b> GD-100	<b>HEAVY DUTY PURPOSE</b> 고 중하중용(高 重荷重用)
---------------------------------------	-------------------------------	---

■ Outlines (외형도)

Unit : mm (inch)

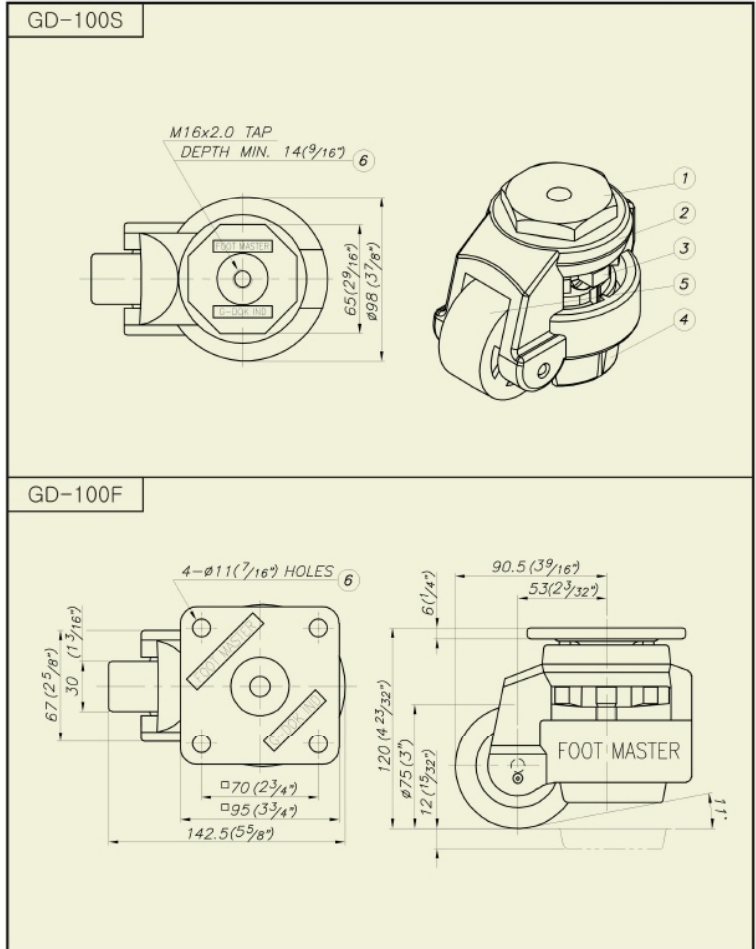

■ Specification (제원)

Load capacity/pce (개당 허용하중)	750 kg (1,650 lbs)	
Recommended load/4 pcs (4개당 추천하중)	1,500 kg (3,300 lbs)	
Net weight (자중)	S-type	1.6 kg (3.6 lbs)
	F-type	1.9 kg (4.2 lbs)
Temperature range (사용온도)	-10 ~ +90℃ (+14 ~ +194°F)	

■ Material (재질)

① Top plate (취부판)	F-type : Pressed steel / S-type : Forged steel	
② Frame (몸체)	Aluminum diecasted	
③ Handle (핸들)	ABS	
④ Leveling pad (받침대)	NBR (Polyurethane, Anti-static polyurethane available by order)	
⑤ Wheel (바퀴)	Nylon-6 / U-type : Polyurethane with aluminum core	
⑥ Mounting bolt (취부볼트)	S-type	M16x2.0P
	F-type	4-M10x1.5P
⑦ Surface treatment (표면처리)	Powder coated & Zinc galvanized	